

118

BEDSIDE TABLE

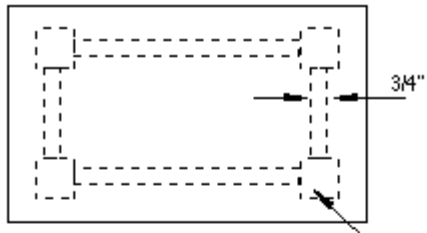



OAK
CHERRY
MAHOAGANY

WALNUT
WILLOW
MAPLE

1-1/2" sq.

RAILS DOWELED
TO THE LEGS

RAILS SCREWED
TO THE TOP

SHELF FITS
INTO DADOES
IN THE LEGS

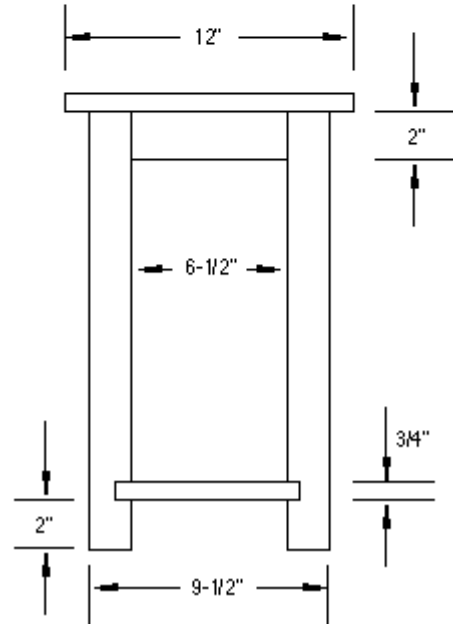
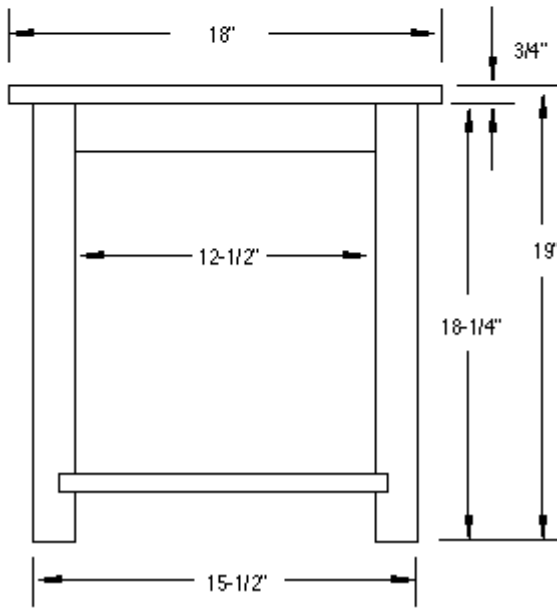
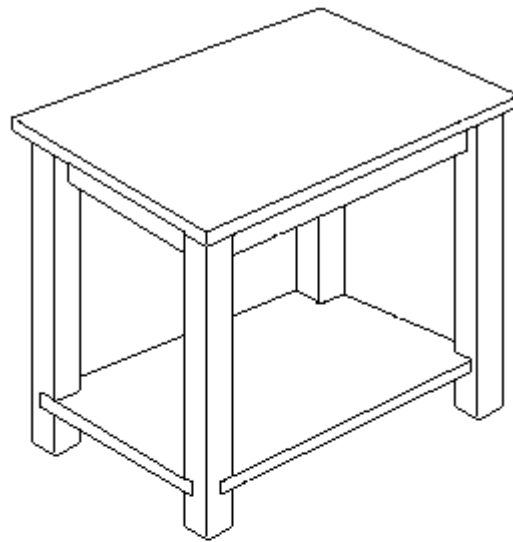

Procedure

I. Top and Shelf

1. Lay out rough dimensions of all parts on wood.
2. Cut pieces to rough dimension lengths.
3. Joint one edge of each piece.
4. Cut and glue pieces edge to edge to make the top. (Glue oversize.)
5. Cut and glue pieces edge to edge to make the shelf. (Glue oversize.)
6. Let glue cure overnight.
7. Plane to 3/4" thick. * If you started with 3/4" stock, keep it as thick as possible.
8. Cut to finished size on the table saw.
9. Sand smooth.

10. Rout the top edge of the top with whatever edge-forming bit you like. * DO NOT ROUT THE SHELF!
11. On the shelf only, cut a 3/4" X 3/4" square off each corner to fit into the legs.

II. Legs

1. Face-glue two 3/4" thick by 1 1/2" wide leg pieces to make four leg blanks 1-1/2" X 1-1/2" X 20". Use straight finished wood.
2. Using the router table, rout a 3/8" roundover on each edge.
3. Square cut one end of each leg on the miter box.
4. Measuring from the squared end, mark and cut the other end of each leg to 18-3/4".
5. Sand smooth.

III. Rails

1. Cut rails to 2" wide.* You may wish to cut slightly oversized and joint to 2". Machine the two short rails together as one piece and cut into two short lengths after all machining is done. * Make sure to use proper push blocks and safety procedure for the jointer.
2. Cut one end of each rail square on the miter box or table saw.
3. Measuring from the squared end, mark and cut two long rails at 12-1/2" and one extra long rail into two short rails at 6-1/2".
4. Drill a 3/8" hole 1" into the edge of each rail. Then drill a 9/64" pilot hole the rest of the way through. (The holes will be used to attach the top to the table.) * The hole should be approximately centered on each piece.
5. Elongate the hole on the upper side by coming in from the top with a drill and carefully wiggling the drill around to end up with a tapered hole. This will allow for a little movement in the table. Wood shrinks and expands with changes in temperature and humidity, and without an allowance for movement, the table could crack at some point in time.

IV. Assembly

1. Take the four legs and cut a 3/4" dado 3/4" deep in two adjacent edges approximately 2" in from one end. * These dados support the shelf.
2. Finish sand all pieces.
3. Use either dowels or biscuits to attach the rails to the legs.* You must insert the shelf before you glue the rails to the legs.
4. Attach the top using four #6 X 1-5/8" drywall screws. * The screws slide through the holes that you drilled in your rails.