

109

**ARTS AND CRAFTS
CHAIR**

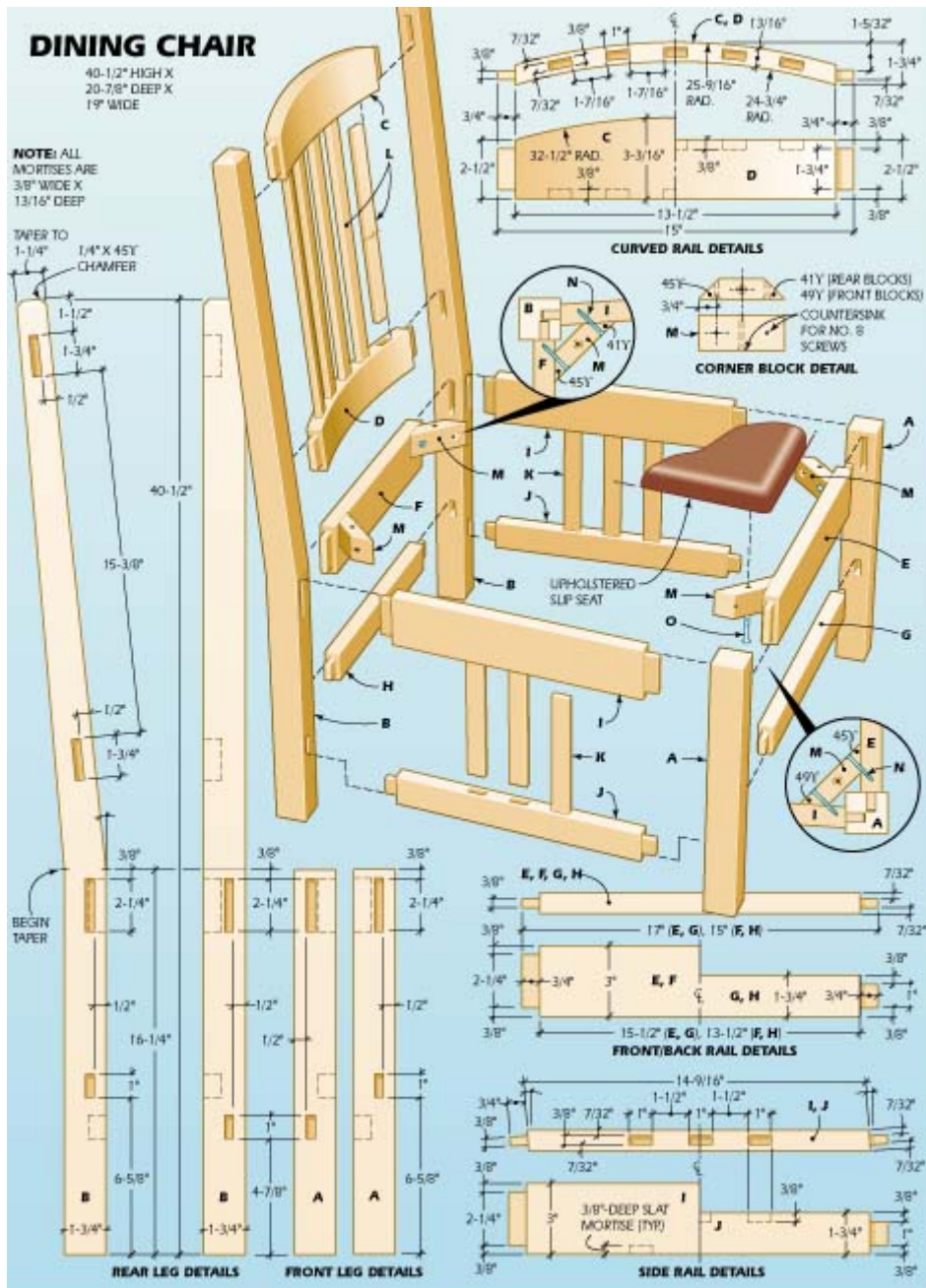



MATERIALS LIST--DINING CHAIR		
Key	No.	Size and description (use)
A	2	1-3/4 x 1-3/4 x 16-1/4" oak (front leg)
B	2	1-3/4 x 3-3/4 x 40-1/2" oak (rear leg)
C	1	1-3/4 x 3-3/16 x 15" oak (top rail)
D	1	1-3/4 x 2-1/2 x 15" oak (bottom rail)
E	1	13/16 x 3 x 17" oak (top front rail)
F	1	13/16 x 3 x 15" oak (top back rail)

		rail)
G	1	13/16 x 1-3/4 x 17" (lower front rail)
H	1	13/16 x 1-3/4 x 15" oak (lower back rail)
I	2	13/16 x 3 x 16-1/4" oak (top side rail)
J	2	13/16 x 1-3/4 x 16-1/4" (lower side rail)
K	6	3/8 x 1 x 7-3/4" oak (side slat)
L	5	3/8 x 1 x 15-3/8" oak (back slat)
M	4	13/16 x 1-1/2 x 3-5/8" (corner block)
N	8	1-1/2" No. 8 fh woodscrew
O	4	2-1/4" No. 8 fh woodscrew
Misc.: Medium Fumed Oak aniline dye (No. W1190)		

Making The Parts

Begin construction by ripping and crosscutting stock to size for the front legs. Then, cut two 4 x 42-in. blanks for the rear legs. Make a cardboard template for the rear legs and trace around it to transfer the shape to each blank. Saw to the waste side of the line with a band saw or sabre saw, and use a sharp plane to trim each leg square and to finished dimension (Photo 1).

Mark the mortise locations on all legs. To make this job easier, clamp several legs together with the ends held even and mark across them using a straightedge or square as a guide. Install a 3/8-in.-dia. spiral up-cutting bit in your router, and use an edge guide to rout the mortises in the legs (Photo 2). Square the rounded mortise ends with a sharp chisel.

Cut blanks of 1-3/4-in.-thick stock for the curved back rails. Before cutting their curved profiles, use a table saw and dado blade to cut the tenons at the ends of the pieces (Photo 3). Note that the tenons are not centered across the thickness of the blanks. Cut one side of all the tenons first, then readjust the blade height to cut the other side. It's best to cut the tenons about 1/32 in. thicker than indicated, and then use a sharp chisel to pare the surfaces smooth and bring the tenons to finished dimension.

Make a cardboard template for the back-rail shape and use it to transfer the shape to each blank. Use a band saw to cut the inside curve of each rail (Photo 4). Then, remove the saw marks and smooth the curved shape with a spokeshave (Photo 5). Go back to the band saw to cut the outside curve and smooth that surface with either a block plane or spokeshave. Don't cut the arched profile of the top rails at this time.

Cut stock for the lower front and back rails to finished dimension and use a dado blade in the table saw to cut the tenons. Readjust the blade height and hold the rails on edge to cut the top and bottom shoulders at each rail end.

Next, cut stock to size for the side rails. Study the drawing to be sure you understand the angled tenons on these pieces. Label each rail with its

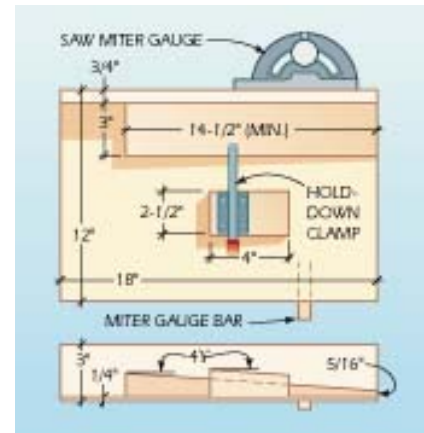

ANGLED-TENON JIG



After sawing the rear leg shape, use a sharp plane to remove saw marks and trim the leg to exact size.

location in the chair to avoid confusion when it comes time to cut the joints.

We built a jig to cut the angled tenons. To make the jig, first attach a hardwood fence to a plywood base, and then screw the assembly to your table saw miter gauge. Glue up four pieces of 3/4-in.-thick stock and band saw the stack into a ramp with an angle of 4°. Screw the ramp to the plywood base. To use the jig, hold a rail on the ramp and push the jig past the dado blade. We used a holddown clamp mounted on a tapered hardwood block to hold the workpiece.



Mark the mortise locations in the chair legs, and use a plunge router with an edge guide to cut the mortises.



Use a table saw and dado blade to cut the tenons in the blanks for the curved back rails. These tenons are not centered.



Lay out the back-rail curve onto the edge of each rail blank. Then, cut the inside curve on the band saw.



Use a spokeshave to smooth the inside curve of the back rail, and then cut and smooth the outer curve.

Cut one surface of each tenon with the ramp angled down toward the dado blade (Photo 6). Then, secure the ramp in the opposite direction and readjust the blade height for the opposite side of each tenon (Photo 7). If you're using the holddown clamp, you'll need to remount it. Then, use the miter gauge without the jig to make the angled cuts for the top and bottom shoulders of the side rails (Photo 8). Cut strips for the side and back slats. Crosscut the slats to finished length, and set them aside.

Lay out the slat mortises in the side rails and in the curved back rails. Mark the side-rail mortises by clamping several rails together and marking across the stack with a square. Mark the curved rails individually.

Install a 5/16-in.-dia. bit in the drill press and bore slightly overlapping holes to remove most of the waste from the mortises in both the curved and straight rails (Photo 9). Then, use a sharp chisel to pare the walls and square the ends of the mortises (Photo 10). Test a slat in each mortise--the fit should be snug. Make another template for the arched shape of the top back rail and use the template to trace the shape onto the workpiece. Use a sabre saw to cut the profile (Photo 11).



To cut the angled tenons on the side rails, support the stock in a table saw jig that holds the work at a 4° angle.



When cutting the opposite tenon faces on the rails, reverse the ramp on the jig and readjust the dado blade height.



Finish the rail tenons by cutting the top and bottom shoulders with the miter gauge and dado blade.



Use a 5/16-in.-dia. bit to bore slightly overlapping holes to remove most of the waste from each slat mortise.



Trim and square the slat-mortise walls with a sharp chisel. Then, test fit the slats--they should be quite snug.



Use a template to lay out the arched profile of the upper back rail. Then, cut to the line with a sabre saw and smooth.

Mark the shoulders on the top and bottom edges of the curved back rails and use a small backsaw to make the cuts (Photo 12). First, make the cuts into the endgrain of the tenon. Then finish the shoulder by cutting across the grain.

Place guide marks for the 1/4-in. chamfer at the top end of each rear leg. Clamp a leg in the bench vise and use a sharp block plane to cut the chamfers.

Assembly

First, sand all parts with 120-, 150-, 180- and 220-grit paper, dusting off thoroughly between grits.

Spread glue on the mating surfaces for the front-leg/front-rail joints. Use a small shim to spread glue in the leg mortises and a small brush for the tenons. Spread the glue sparingly on the tenons to avoid excessive squeeze-out at the joints.

Join the rails to the front legs, then clamp the joints and compare opposite diagonal measurements to be sure the assembly is square (Photo 13). Let the glue set for about 20 minutes and use an old chisel to pare off any excess glue.

Next, insert the side slats in the mortises of the bottom side rails and position the top side rail over the slat ends. While you don't need glue in the slat joints, a drop of glue in a loose joint will keep the slat from rattling. Temporarily clamp the rails and slats (Photo 14).

Spread glue in the open mortises of the front-leg assembly and on the front tenons of the side rails, and join the side rails to the legs (Photo 15).

Join the back slats to the curved rails (Photo 16) and temporarily clamp the assembly. Again, it's not necessary to glue these joints unless a slat is loose in its mortise.

Spread glue on the tenons of the back rails and in the matching mortises in the back legs. Join the rails to the legs, clamp and compare opposite diagonal measurements (Photo 17).



Cut the shoulders of the curved back rail tenons with a small backsaw. First cut in from the end, then across the grain.



Join the front rails to the legs, and clamp. Compare opposite diagonal measurements to check for square.



Join the side slats to the rails. It's not necessary to use glue since the slats are held captive between the rails.



Spread glue on the rail and leg mating surfaces. Join the side rails to the front leg assembly and clamp.



Join the back slats to the curved rails. If a slat is too loose in its mortise, add a drop of glue to keep it from rattling.



Join the back rail and slats to the legs. Apply the glue sparingly, clamp, and check that the diagonals are equal.

Once the glue has set on the subassemblies, complete the chair frame by joining the side rails to the back-leg assembly. Spread glue on the mating surfaces and position the joints. Apply clamps to pull the joints tight. Set the chair upright on a flat worktable to be sure that all four legs sit evenly (Photo 18). Adjust the clamps and joints, if necessary, until any rocking is eliminated.

Cut corner blocks to reinforce the joints and provide a means for attaching the seat. Note that the angles for the blocks at the front of the chair are different than those for the rear blocks. Use a miterbox to cut the blocks. If your miterbox won't handle the 41° angle for the rear blocks, make the cuts on a band saw.

Bore and countersink pilot holes through the width of the blocks for attaching the seats. Use a clamp to hold each block in place while you bore and countersink pilot holes for attaching it to the rails (Photo 19). A combination bit and countersink is the most efficient tool for the job. Fasten the blocks to the rails with 1-1/2-in. No. 8 screws.

Finishing

First inspect each chair for scratches, and sand if necessary. We used a water-soluble aniline dye for a beautiful, clear and lightfast color. To eliminate raised grain problems, wipe the chairs with a sponge dampened with clean water. Let the wood dry completely and lightly sand the surface with 220-grit paper.

Follow the manufacturer's directions for mixing and applying the dye, and be sure to allow sufficient drying time before applying a finish.

For our finish, we used Waterlox Original Sealer/Finish. Brush or wipe on the first coat, which will soak into the wood readily. Allow the finish to dry overnight. Lightly sand with 320-grit paper and remove all dust. For the next and subsequent coats, apply the finish and let it sit for about 30 minutes before wiping off any excess. Then, let the finish dry overnight. At this point, you will sand between coats only if the finish is rough. After three or four coats, burnish the surface with 4/0 steel wool to remove any rough spots, and polish with a soft cloth.

Finally, attach the finished slip seats to the frames with screws installed through the corner blocks into the underside of each seat.



Join the back subassembly to the front-leg/side-rail assembly. Work on a flat surface so the legs remain even.

